

Thule System Kit 136

IMPORTANT!

By carefully following these written instructions, installation of this kit should be quick and easy. However, because proper installation is greatly dependent on the skill exercised in removing the rivets from the door frame(s), **THULE strongly recommends installation by a qualified professional.** No warrant is given for defects or vehicle damage resulting from failure or inability to mount the load carrier in accordance with written THULE instructions.

For certain accessories such as a Combi Box it is necessary to remove the factory

rack load bars (if applicable). Use a Torx-20 screwdriver to remove the load bar. **Tools required:** Electric drill, metal drill bit 3/16" or 5 mm, pliers.

1/ Identify rivets to be removed in rubber gasket. Plastic plugs must be removed from the Explorer two door and Navajo.

2/ Place 3/16" or 5 mm drill bit into center of rivet and **very slowly and carefully** drill out the rivet. Always use protective eyewear when using power tools. Only drill in far enough to remove the rivet—do not drill all the way into the rivet hole in the roof.

CAUTION: Use very light pressure when drilling the rivet. The material is very soft and quite easily penetrated. Excessive force will cause the drill bit to rapidly cut through the rivet and strike the inside wall, possibly breaking the bit. Use a pair of pliers to remove the plastic plug from the Explorer two door and Navajo.

3/ Place attachment clips behind rubber gasket. Make sure to line up the hole in the clips with the hole in the gasket and roof. Using a screwdriver, secure attachment clips tightly with screws provided in kit.

Note: When threading the self-tapping sheet metal screws into the door frames it is recommended that a sealant (caulking compound, silicone, pipe joint compound, etc.) is applied to the threads to prevent water from migrating through the threads.

The self-tapping screws and attachment clips are designed to be **permanently** installed on the vehicle. Do not remove the screw after installation. Each time a screw is removed and reinstalled, the holding power of the fastener is reduced. You can remove the load carrier and upper mounting bracket with no effect on the security of the system.

FORD Explorer 4-dr, 91-

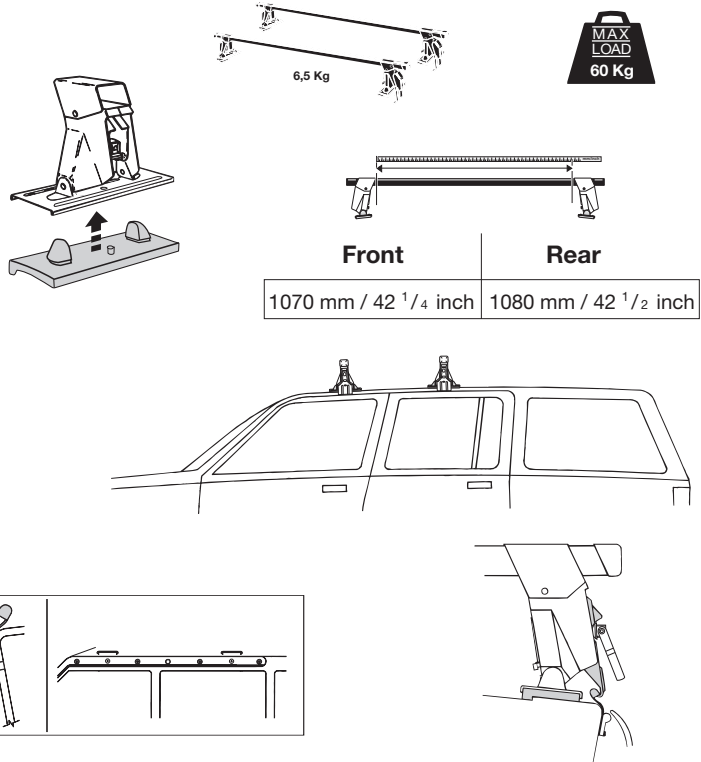
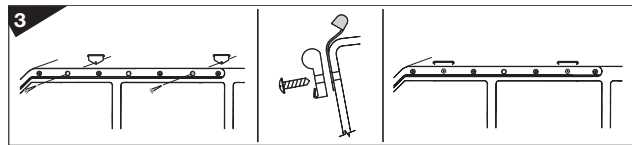
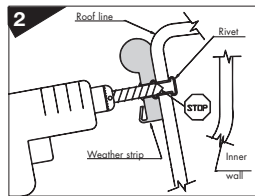
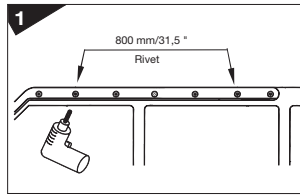
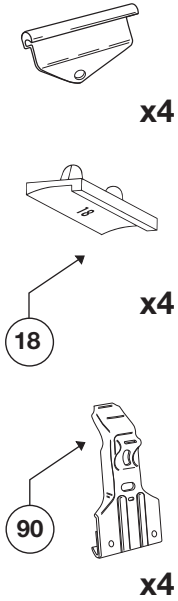

FORD Explorer 2-dr, 91- MAZDA Navajo, 91-

