

Toyota 4 Runner, 96-



Den tillåtna lasten får inte överskridas. Beakta dock bilfabrikantens instruktion för tillåten last.
Max last = lasthållarens vikt + lastens vikt.

The maximum recommended load must not be exceeded, and the car manufacturer's directions as to maximum recommended load must be observed.
Maximum load = the weight of the load carriers + the weight of the load.

Das zulässige Gesamtgewicht des Kraftfahrzeugs darf nicht überschritten werden. Die Anweisungen des Kraftfahrzeugherstellers hinsichtlich der empfohlenen Dachlast müssen beachtet werden.
Dachlast = Gewicht des Lastenträgers + Gewicht der Last.

La charge utile ne doit pas être dépassée, et les directives du constructeur automobile concernant la charge maximum doivent être respectées.
Charge maximum = le poids du porte-charge + le poids du chargement.

Het maximum aanbevolen laadgewicht mag in geen geval overschreden worden en de voorschriften van de autofabrikant met betrekking tot het maximum aanbevolen laadgewicht dienen te worden gevolgd.
Het maximum laadgewicht = het gewicht van de allersdrager + het gewicht van de lading.

Taakkatelineen sallittua painolastia ei saa ylittää. Auton valmistajan ohjeet on kuitenkin otettava huomioon.
Maksimipainolasti = taakkatelineen paino + lastin paino.

La carga máxima recomendada no debe ser excedida y tener en cuenta las instrucciones del fabricante en lo que respecta a las carga máximas recomendadas.
Carga máxima = peso del portacargas + peso de la carga.

Il peso massimo del carico non deve superare quello consigliato, e le istruzioni date dal fabbricante della vettura devono essere rispettate.
Carico massimo = il peso delle barre portatutto + il peso del carico.

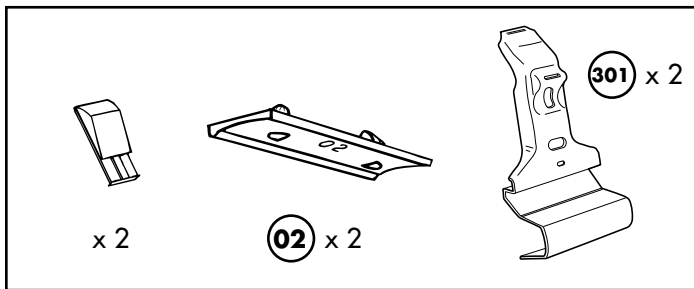

**FRAM/FRONT/VORNE
AVANT/VOOR/ETU
DELANTE/DAVANTI/フロント**
986 mm ± 5mm
38 7/8 inch ± 1/4 inch

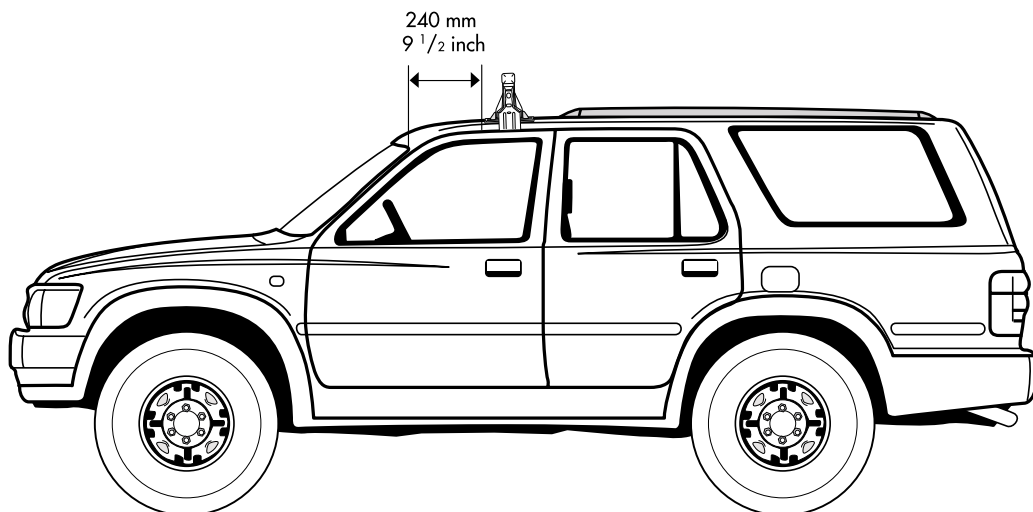
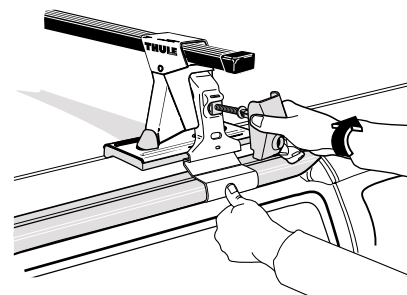
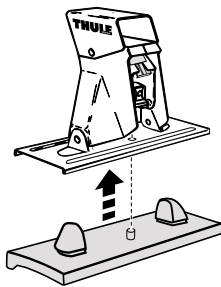
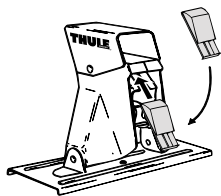

Ford Excursion, 00-



Den tillåtna lasten får inte överskridas. Beakta dock bilfabrikantens instruktion för tillåten last.
Max last = lasthållarens vikt + lastens vikt.

The maximum recommended load must not be exceeded, and the car manufacturer's directions as to maximum recommended load must be observed.
Maximum load = the weight of the load carriers + the weight of the load.

Das zulässige Gesamtgewicht des Kraftfahrzeugs darf nicht überschritten werden. Die Anweisungen des Kraftfahrzeugherstellers hinsichtlich der empfohlenen Dachlast müssen beachtet werden.
Dachlast = Gewicht des Lastenträgers + Gewicht der Last.

La charge utile ne doit pas être dépassée, et les directives du constructeur automobile concernant la charge maximum doivent être respectées.
Charge maximum = le poids du porte-charge + le poids du chargement.

Het maximum aanbevolen laadgewicht mag in geen geval overschreden worden en de voorschriften van de autofabrikant met betrekking tot het maximum aanbevolen laadgewicht dienen te worden gevolgd.
Het maximum laadgewicht = het gewicht van de allersdrager + het gewicht van de lading.

Taakkatelineen sallittua painolastia ei saa ylittää. Auton valmistajan ohjeet on kuitenkin otettava huomioon.
Maksimipainolasti = taakkatelineen paino + lastin paino.

La carga máxima recomendada no debe ser excedida y tener en cuenta las instrucciones del fabricante en lo que respecta a las carga máximas recomendadas.
Carga máxima = peso del portacargas + peso de la carga.

Il peso massimo del carico non deve superare quello consigliato, e le istruzioni date dal fabbricante della vettura devono essere rispettate.
Carico massimo = il peso delle barre portatutto + il peso del carico.

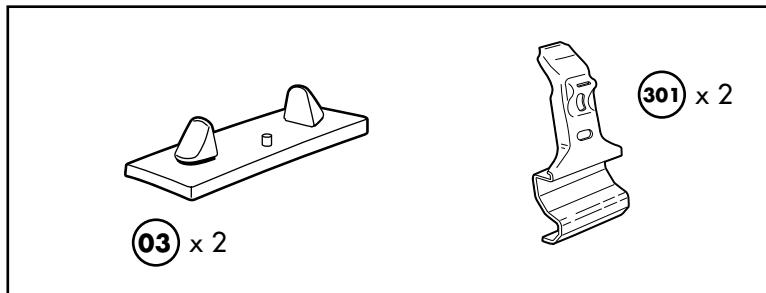

**FRAM/FRONT/VORNE
AVANT/VOOR/ETJ
DELANTE/DAVANTI/フロント**
1300 mm ± 5mm
51 1/8 inch ± 1/4 inch

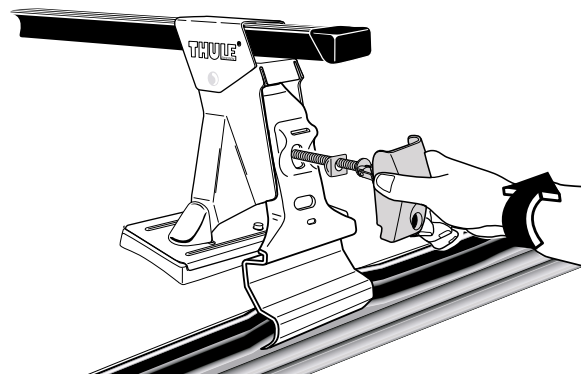
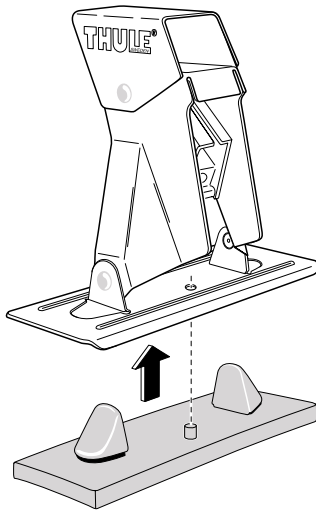
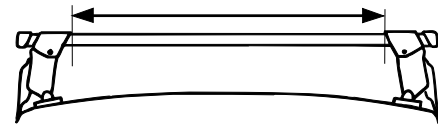

270 mm
10 5/8 inch

