

Thule System Kit 092

NISSAN 200 SX, (S13) 89-



GB

The adapter brackets are designed for permanent installation on your vehicle.

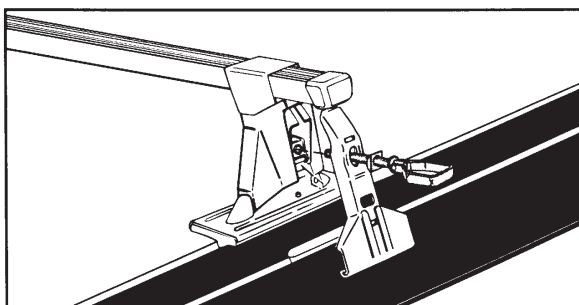
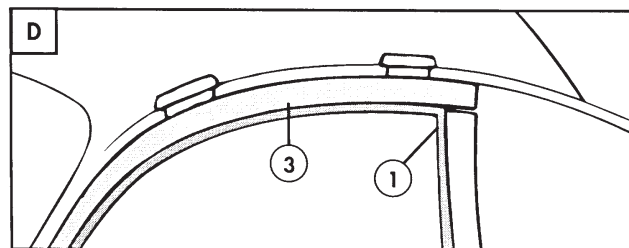
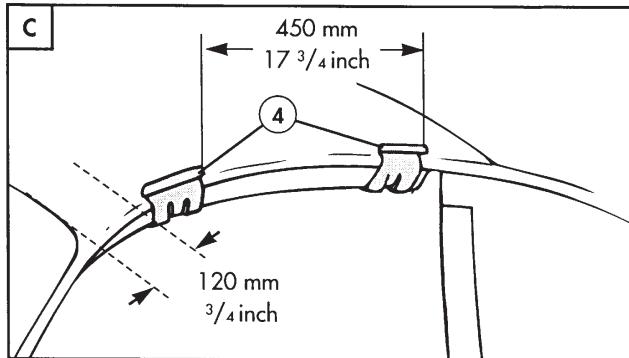
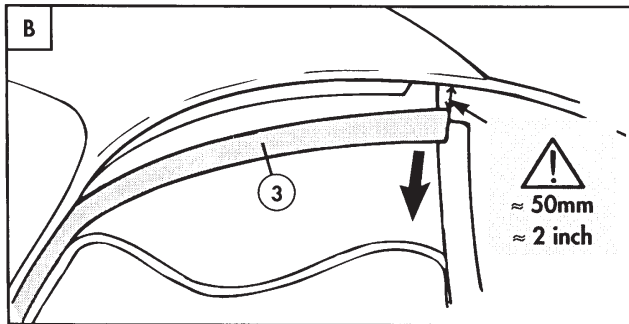
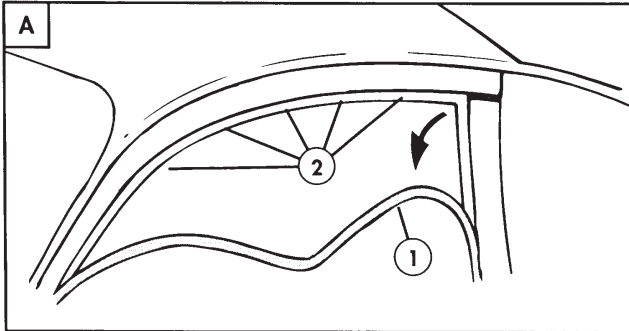

GB FIG A. Loosen the rubber door seal (1) in the corner, by pulling it gently from the vehicle. Do not detach it completely.

After loosening the seal, remove only 5 of the crosshead screws (2) on the inside of the roof profile.

FIG B. After loosening the seal and removing the 5 crosshead screws, the black strip (3) can be separated (with care!) from the vehicle approx. 5 cm.

GB FIG C. Fasten the adapter brackets (4) to the coachwork rim, positioning them as shown. The distances shown must be observed.

FIG D. Refasten the roof strip (3) and door seal (1) in reverse order to that in which they were loosened (Fig B + A). If necessary, the spacers on the inside of the roof strip should be removed.

If the roof strip does not lie flat when refastened, remove some of the foam before refastening it in position. If, as a result, water leaks into the car, the strip should be resealed.